

Superfinish Ball Lapping Machine SLM 40 (EL)



SpezialMaschinenfabrik-**S**chonungen-GmbH
D-97453 Schonungen

Technical data

Superfinish Ball Lapping Machine SLM 40 (EL)

Working range:	Smallest ball diameter	[mm]	1
	Largest ball diameter	[mm]	8
Machining pressure:	maximum	[kN]	15
Compressive force control:	automatically		
Lapping precision:	Sphericity	according to ball diameter and DIN 5401	
	Surface quality (CLA)	according to ball diameter and DIN 5401	
	Load tolerance	according to ball diameter and DIN 5401	
Lapping disks:	Special cast iron		
Outer diameter		[mm]	400
Inner diameter		[mm]	164
Thickness		[mm]	80
Speed		[min ⁻¹]	20 - 120
Standard ring magazine:	Outer diameter	[mm]	844
Capacity, max.		[kg]	50
Speed range		[min ⁻¹]	0,05-1,60
Driving data:	Total power supply	[kW]	3,2
Main drive:	Power	[kW]	2,2
	Speed	[min ⁻¹]	1000
Ring magazine drive:	Power	[kW]	0,25
	Speed	[min ⁻¹]	1500
Vertical adjustment of the ring magazine:	Power	[kW]	0,12
	Speed	[min ⁻¹]	3000
Vertical adjustment of the lapping disks (el.-mech.)	Power	[kW]	0,12
	Speed	[min ⁻¹]	3000
Ball Pushing Device:	Power	[kW]	0,048
	Speed	[min ⁻¹]	3000
Lapping medium pump:	Power	[kW]	0,5
	Speed	[min ⁻¹]	3000
	Conveying capacity	[l/min]	160
Space requirement:	Lenght x width	[mm]	1750 x 1000
Total height		[mm]	2050
Weight:	net	[kg]	235
	gross	[kg]	1550
Case measurements:	Lenght x width x height	[mm]	1400x1300x2280
Volume		[m ³]	4,2

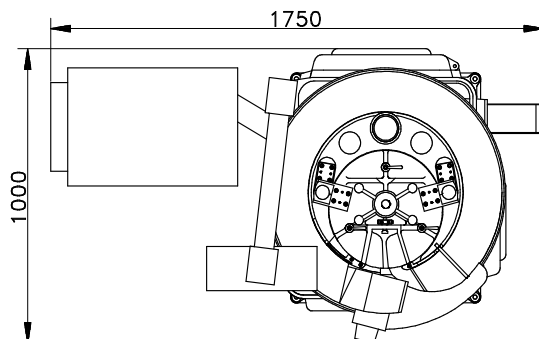

Construction modifications reserved



SpezialMaschinenfabrik-Schonungen-GmbH

Jahnstraße 6

D-97453 Schonungen near Schweinfurt

Telefon: +49 (9721) 750 901 -0

Telefax: +49 (9721) 750 901 -9

E-Mail: sms@sms-schonungen.de

Internet: www.sms-schonungen.de